

Differential Pressure Gauge

With Integrated Working Pressure Gauge

DELTA-plus

Model 702.01.100

Pressure Gauges

- The working pressure gauge integrated as a standard feature enables the central monitoring of differential pressure and working pressure in one measuring instrument
- Differential pressure measuring ranges from 0 ... 250 mbar to 0 ... 25 bar
- High working pressure (static pressure) 25 bar
- Overload value either side 25 bar
- Solid case construction as protection against external mechanical effects
- Integrated pressure equalizing valve as optional extra
- Three cast-on mounting brackets for wall mounting
- Long service life
- Optimal price/performance ratio



DELTA-plus with compression fitting with ferrule (optional extra)

General features

These differential pressure gauges are particularly intended for the monitoring of differential pressures in filter systems, pumps and pipeline systems in the heating, climatic and ventilating technology sector, technical building equipment and in the water management industry.

Apart from the display of the differential pressure, these applications require, as a rule, the display of the current working pressure. For this reason, a working pressure gauge is integrated in the differential pressure gauge *DELTA-plus* as a standard feature. An additional measuring point involving additional expenses for piping and mounting is thus no longer required.

The white dial of the working pressure gauge distinctly stands out against the blue background of the display of the differential pressure gauge, thus enabling a quick and safe reading of both quantities to be measured.

The ranges of 0 ... 250 mbar up to 0 ... 25 bar provide the measuring ranges, which are required in the most different applications. The sturdy and compact design of the differential pressure gauge makes it possible to use it even under tough industrial ambient conditions.

Supplementary data sheets

- Differential pressure gauge with integrated working pressure gauge and microswitch
Model 702.02.100 (see data sheet PM 07.16) *DELTA-comb*
- Differential pressure switch Model 851.02.100 (see data sheet PM 07.17) *DELTA-switch*
- Differential pressure transmitter Model 891.34.2189 (see data sheet PM 07.18) *DELTA-trans*

Main applications

- Heating, climatic and ventilating technology
- Dust removing technology
- Technical building equipment
- Filter plants
- Drinking and service water treatment
- Monitoring of pumps

Suitable for all gaseous and liquid media that will not obstruct the pressure system.

Design and operating principle

Pressure p_1 and p_2 are given in the \oplus and \ominus measuring medium chambers separated by an elastic diaphragm (1).

The differential pressure ($\Delta p = p_1 - p_2$) causes axial movement (measuring travel) of the diaphragm against the measuring range spring (2).

The transmission of the differential pressure proportional to the measuring travel to the movement (4) within the indicating case is carried out pressure sealed and with little friction by means of a connecting rod (3).

The overpressure protection is provided by contoured metal bolsters for the elastic diaphragm (5).

Illustration of operating principle

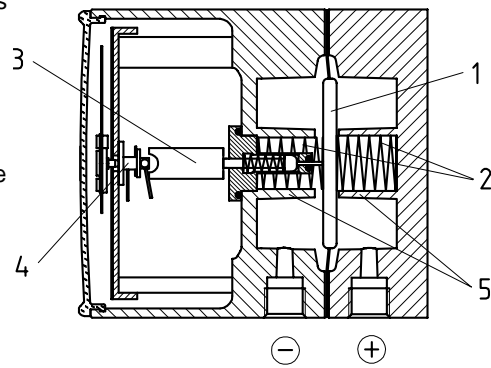

2156 661.01

Technical data

Nominal size

Differential pressure gauge: \varnothing 100 mm
Working pressure gauge: \varnothing 23 mm

Accuracy class

Differential pressure gauge: 2.5
Working pressure gauge: 4

Scale ranges per EN 837

Differential pressure: 0 ... 0.25 to 0 ... 25 bar
Working pressure: 0 ... 25 bar

Working pressure max. (static pressure)
25 bar

Overpressure safety

Either side max. 25 bar

Operating temperature

Ambient: -10 ... +70 °C
Medium: +90 °C maximum

Ingress protection

IP 54 per EN 60 529 / IEC 529

Measuring media chamber (exposed to pressure medium)

GD-AISI 12 (Cu) 3.2982, black painted

Pressure connections (exposed to pressure medium)

2 x G 1/4 female, bottom, in-line, axle base 26 mm

Pressure elements (exposed to pressure medium)

Differential pressure: Compression spring of stainless steel 1.4310 and separating diaphragm of NBR fabric back stay (optional FPM/Viton)
Working pressure: Bourdon tube Cu-alloy

Links (exposed to pressure medium)

Stainless steel 1.4104, NBR (optional FPM/Viton)

Sealing rings (exposed to pressure medium)

according to membrane material, NBR or FPM/Viton

Movement

Cu-alloy, wear parts German silver

Dial

Differential pressure gauge: blue aluminium with white lettering
Working pressure gauge: white plastic with black lettering

Pointer

Differential pressure gauge: white aluminium adjustable pointer
Working pressure gauge: black plastic

Zero adjustment for differential pressure gauge

By means of adjustable pointer

Case

GD-AISI 12 (Cu) 3.2982, black painted

Window

acrylic

Weight

approx. 1.3 kg

Gauge mounting

Pressure entries identified \oplus and \ominus ,
 \oplus high pressure, \ominus low pressure
Mounting by means of rigid tailpipes or wall mounting with mounting brackets

Optional extras

- Pressure media chamber GD-AISI 12 (Cu) HART-COAT surface protection
- Pressure media chamber of stainless steel (without working pressure gauge)
- Accuracy class 1.6 for differential pressure gauge with scale ranges 0 ... 1 bar to 0 ... 25 bar
- Ingress protection IP 65
- Integrated pressure equalizing valve stainless steel and NBR or FPM/Viton according to membrane material
- 4-way valve manifold Cu-alloy or stainl. steel (1x press. equalising valve, 2x pressure gauge valve, 1x valve for purging or air bleeding)
- Other threaded pressure connections female or male
- Compression fitting with ferrule for pipe \varnothing 6, 8 or 10 mm
- Front flange for panel mounting

Dimensions in mm

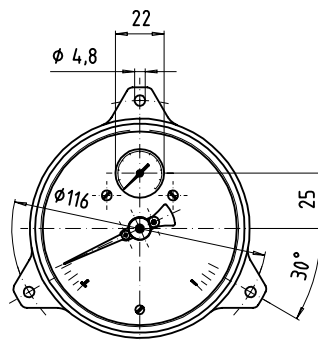
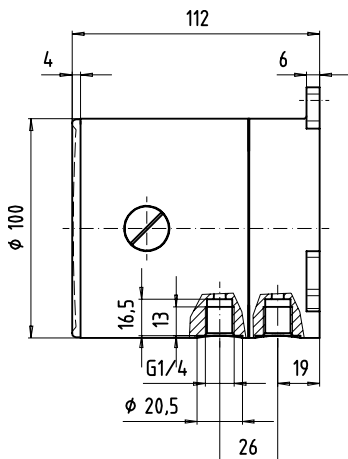

2123 541.01

Other process connections as optional extra

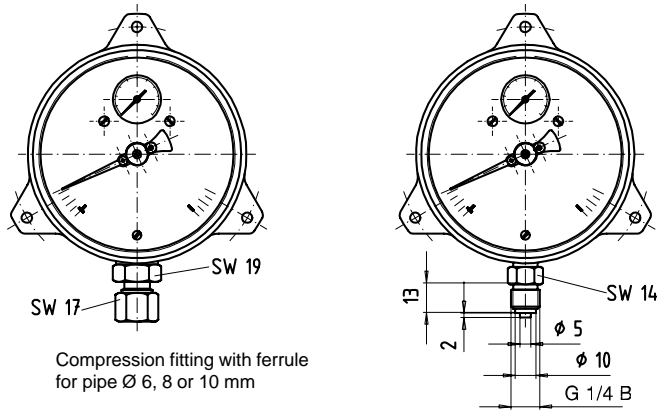

Panel mounting as optional extra

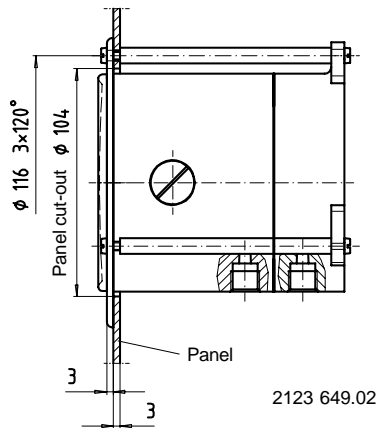

Integrated pressure equalizing valve as optional extra

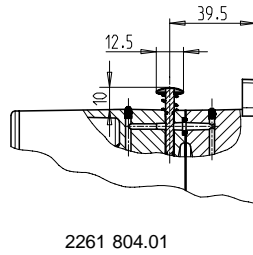

4-way valve manifold as optional extra

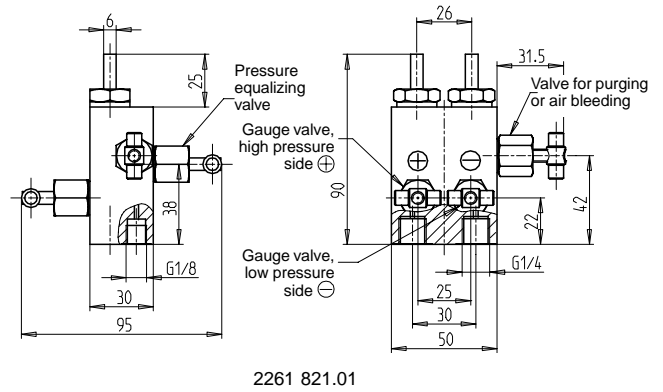

Order code for Differential Pressure Gauge with integrated working pressure gauge

DELTA-plus Model 702.01.100

Field No.	Code	Instrument design
1		Unit
	B	bar
	?	other <i>Please state as additional text</i>
		Measuring range
	AN	0 ... 0.25 bar
	BB	0 ... 0.4 bar
	BC	0 ... 0.6 bar
	BD	0 ... 1 bar
	BE	0 ... 1.6 bar
	BF	0 ... 2.5 bar
	BG	0 ... 4 bar
	BH	0 ... 6 bar
BI	0 ... 10 bar	
BK	0 ... 16 bar	
BL	0 ... 25 bar	
2	??	other <i>Please state as additional text</i>
		Process connection
	AA	2 x G 1/4 female <i>standard</i>
	AM	2 x G 1/4 B Cu-alloy
	AN	2 x G 1/4 B stainless steel
	DA	compression fitting with ferrule, steel for pipe Ø 6 mm
	DB	compression fitting with ferrule, steel for pipe Ø 8 mm
	DC	compression fitting with ferrule, steel for pipe Ø 10 mm
	DE	compression fitting with ferrule, stainless steel for pipe Ø 6 mm

Field	Code	Instrument design
3	-	compression fitting with ferrule, stainless steel for pipe Ø 8 mm
	DG	compression fitting with ferrule, stainless steel for pipe Ø 10 mm
	DK	compression fitting with ferrule, Cu-alloy for pipe Ø 6 mm
	DL	compression fitting with ferrule, Cu-alloy for pipe Ø 8 mm
	DM	compression fitting with ferrule, Cu-alloy for pipe Ø 10 mm
	??	other <i>Please state as additional text</i>
Pressure media chamber		
4	A	aluminium, black painted <i>standard</i>
	H	aluminium HART-COAT
	C	stainless steel, without working pressure gauge
	?	other <i>Please state as additional text</i>
Separation diaphragm / Sealing rings		
5	G	NBR <i>standard</i>
	J	FPM/Viton
Accuracy class for differential pressure gauge		
6	4	class 2.5 <i>standard</i>
	3	class 1.6 <i>scale ranges 0 ... 1 bar and up</i>
Mounting flange / bracket		
7	Z	without <i>standard</i>
	D	front flange, black steel
	?	other <i>Please state as additional text</i>
Ingress protection		
8	F	IP 54 <i>standard</i>
	I	IP 65
Valve manifold / Pressure equalizing valve		
	Z	without <i>standard</i>
	I	integrated pressure equalizing valve
	M	4-way valve manifold, Cu-alloy

Order code for **DELTA-plus** Model 702.01.100

	1	2	3	4	5	6	7	8	9	10	11		
702.01-E	-	<input type="text"/>	-	<input type="text"/>	-	<input type="text"/>	<input type="text"/>	<input type="text"/>	<input type="text"/>	<input type="text"/>	-	<input type="text"/>	<input type="text"/>

Additional text: _____

Specifications and dimensions given in this leaflet represent the state of engineering at the time of printing. Modifications may take place and materials specified may be replaced by others without prior notice.

WIKA Alexander Wiegand GmbH & Co.
 Alexander-Wiegand-Straße · 63911 Klingenberg
 ☎ (0 9372) 132-0 · ☎ (0 9372) 132-406/414
 http://www.wika.de · E-mail: info@wika.de