

# Digital Indicator for Panel Mounting

## Model DI25

WIKAI Data Sheet AC 80.02

### Applications

- Plant construction
- Machine tools
- Plastics technology and processing
- Ventilation and air-conditioning technology
- General industrial applications

### Special Features

- Multi-function input for current and voltage signals as well as thermocouples and resistance thermometers
- Ingress protection IP66 (front panel)
- 2 or 3 fully programmable alarm outputs as standard (depending on the instrument version)
- 4 ... 20 mA analogue signal output as standard
- HOLD function



Digital Indicator Model DI25

### Description

The digital indicator DI25 is a competitively-priced, multi-function instrument for a wide variety of measuring tasks.

The multi-function input has 18 different input configurations, which can be selected via the rear connections and also by selection the appropriate input signal with in the instrument configuration. In this way it is possible to connect transmitters with current or voltage signals, and both resistance thermometers or thermocouples to the same instrument.

The measured value can be retransmitted for further processing via an analogue 4 ... 20 mA output (standard) or via an RS-485 Serial Interface (optional).

Other analogue retransmission signals are also available as option.

The basic version of the DI25 indicator features three alarm outputs. Instruments with the optional 24 V transmitter power supply have two alarm outputs available.

With the high ingress protection of the fascia (IP66) the digital indicator DI25 can also be used under extreme operating conditions.

All configuration and programming can be done using the front control keys.

**Specifications**
**Model DI25**

Display	
- Design	7-segment LED
- Process value display (PV-Display)	4-digit, red, height of digits 16 mm
- Set value display (SV-Display)	4-digit, green, height of digits 10 mm
- Indication range	-1999 ... 9999
Input	
- Number and type	1 multi-function input
- Input configuration	Selectable via terminal connections and menu-driven programming
- Measuring time	250 ms
Alarm outputs	
- Number and type	2 or 3 switching contacts (relays) <sup>1)</sup>
- Alarm type output 1 and 2	High alarm, high alarm with standby, low alarm, low alarm with standby
- Alarm type output 3	High alarm, high alarm with standby, low alarm, low alarm with standby, high low alarm
- Switching function	Normally closed or normally open, can be set via keyboard
- Load	AC 230 V, 3 A (resistive load)
HOLD Function <sup>2)</sup>	Selectable: Instantaneous, maximum or minimum value Activation of the HOLD function via connection terminals
Analogue output	
- Output signal	4 ... 20 mA, load $\leq$ 500 $\Omega$ (standard) or {0 ... 20 mA, load $\leq$ 500 $\Omega$ } or {0 ... 1 V, load $\geq$ 100 k $\Omega$ } or {0 ... 5 V, load $\geq$ 500 k $\Omega$ } or {1 ... 5 V, load $\geq$ 500 k $\Omega$ } or {0 ... 10 V, load $\geq$ 1M $\Omega$ }
- Accuracy	$\pm$ 0.3% of the output span
{Transmitter supply} <sup>1)</sup>	DC 24 V $\pm$ 3V, max. 30 mA
{Serial interface} <sup>2)</sup>	RS 485
Electrical connection	Screw terminals
Power supply	AC 100 ... 240 V (permissible voltage: AC 85 ... 264 V), 50/60 Hz or AC/DC 24 V (permissible voltage: AC/DC 20 ... 28 V), 50/60 Hz
Power consumption	approx. 10 VA
Ambient conditions	
- Working temperature	0 ... 50 °C
- Storage temperature	-20 ... +50 °C
- Humidity	35 ... 85 % relative humidity, non-condensing
CE Conformity	Conformity in accordance with 89/336/EWG Interference emission and interference compatibility see EN 61326
Case	
- Material	polycarbonate
- Colour	black
- Ingress protection	Front: IP66; Back: IP00 (per IEC 60529/EN 60529)
- Weight	approx. 300 g
- Mounting	Screw type mounting brackets for a wall thickness from 1 to 15 mm

{ } Items in curved brackets are optional extras for additional price.

1) Instruments with integrated transmitter supply do not feature the alarm output 2.

2) Instruments with serial interface RS 485 do not feature the HOLD function.

Input signal	Measuring span		Measuring error in [%] of the span	
			Standard	Exception
Current signals				
0 ... 20 mA		-1999 ... +9999	± 0.2 % ± 1 digit	-
4 ... 20 mA		-1999 ... +9999	± 0.2 % ± 1 digit	-
Voltage signals				
0 ... 1 V		-1999 ... +9999	± 0.2 % ± 1 digit	-
0 ... 5 V		-1999 ... +9999	± 0.2 % ± 1 digit	-
1 ... 5 V		-1999 ... +9999	± 0.2 % ± 1 digit	-
0 ... 10 V		-1999 ... +9999	± 0.2 % ± 1 digit	-
Thermocouples				
Type K, NiCr-Ni	-200 ... +1370 °C	-320 ... +2500 °F	± 0.2 % ± 1 digit	≤ 0 °C: ± 0.4 % ± 1 digit
	-199.9 ... +400.0 °C	-199.9 ... +750.0 °F	± 2 K	≤ 0 °C: ± 0.4 % ± 1 digit
Type J, Fe-CuNi	-200 ... +1000 °C	-320 ... +1800 °F	± 0.2 % ± 1 digit	≤ 0 °C: ± 0.4 % ± 1 digit
Type R, PtRh-Pt	0 ... 1760 °C	0 ... 3200 °F	± 0.2 % ± 1 digit	≤ 200 °C: ± 6 K
Type S, PtRh-Pt	0 ... 1760 °C	0 ... 3200 °F	± 0.2 % ± 1 digit	≤ 200 °C: ± 6 K
Type B, PtRh-PtRh	0 ... 1820 °C	0 ... 3300 °F	± 0.2 % ± 1 digit	≤ 300 °C: without details
Type E, NiCr-CuNi	-200 ... +800 °C	-320 ... +1500 °F	± 0.2 % ± 1 digit	≤ 0 °C: ± 0.4 % ± 1 digit
Type T, Cu-CuNi	-199.9 ... +400.0 °C	-199.9 ... +750.0 °F	± 2 K	≤ 0 °C: ± 0.4 % ± 1 digit
Type N, NiCrSi-NiSi	-200 ... +1300 °C	-320 ... +2300 °F	± 0.2 % ± 1 digit	≤ 0 °C: ± 0.4 % ± 1 digit
Type PL-II	0 ... 1390 °C	0 ... 2500 °F	± 0.2 % ± 1 digit	-
Type C (W/Re5-26)	0 ... 2315 °C	0 ... 4200 °F	± 0.2 % ± 1 digit	-
Resistance thermometers				
Pt 100 (3-wire)	-200 ... +850 °C	-300 ... +1500 °F	± 0.1 % ± 1 digit	-
	-199.9 ... +850.0 °C	-199.9 ... +999.9 °F	± 0.1 % ± 1 digit	-
JPt 100 (3-wire)	-200 ... +500 °C	-300 ... +900 °F	± 0.1 % ± 1 digit	-
	-199.9 ... +500 °C	-199.9 ... +900.0 °F	± 1 K	-

## Terminal configuration

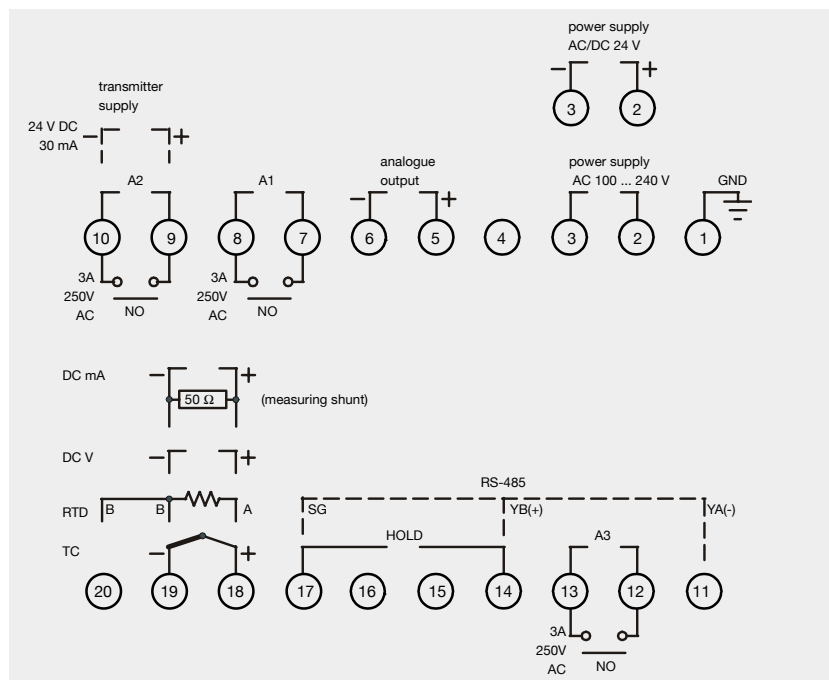

A1, A2, A3	Alarm outputs 1,2 and 3
RTD	Resistance thermometers
TC	Thermocouples
DC mA	Current signals
DC V	Voltage signals
GND	Ground

## Dimensions in mm

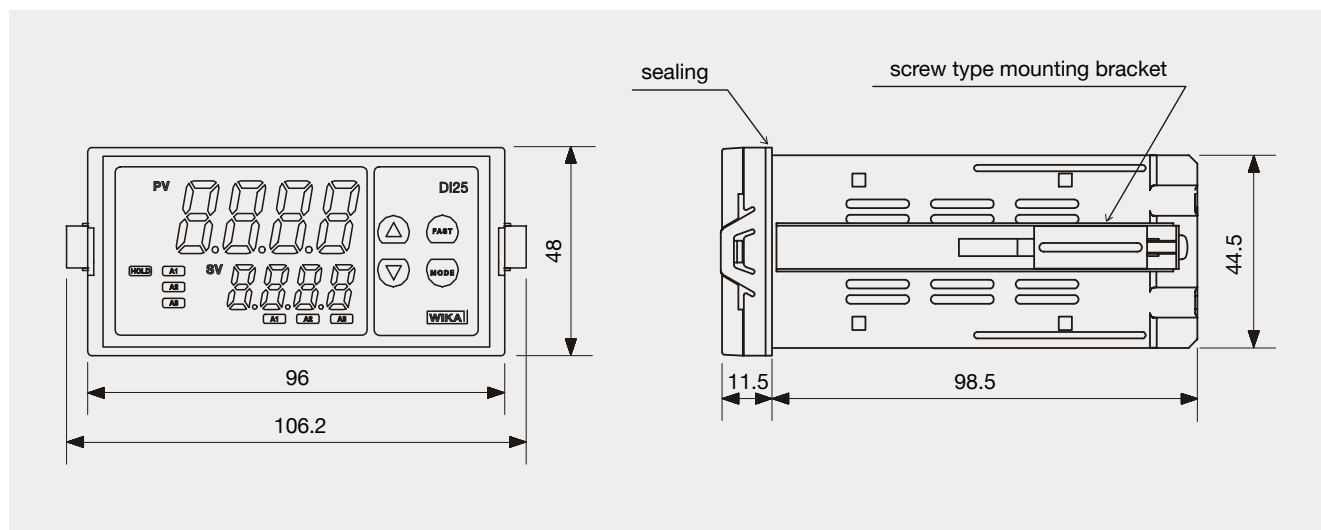

## Panel cutout in mm

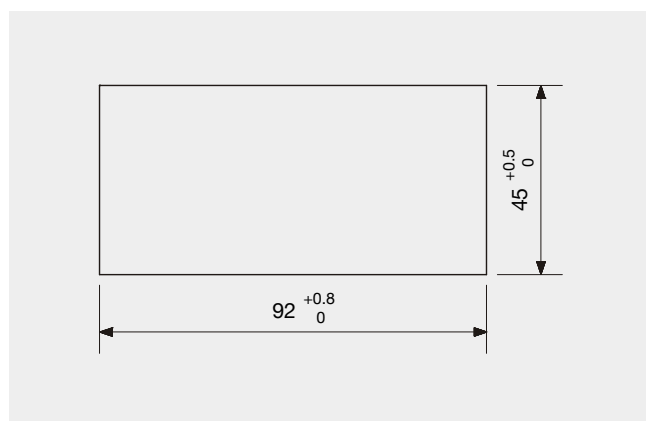

Modifications may take place and materials specified may be replaced by others without prior notice.  
Specifications and dimensions given in this leaflet represent the state of engineering at the time of printing.

